

Signature Series Pendant Mount Adapter

This pendant mount adapter is designed for indoor use. Its robust construction and sleek aesthetics make it a valuable addition to any surveillance installation.

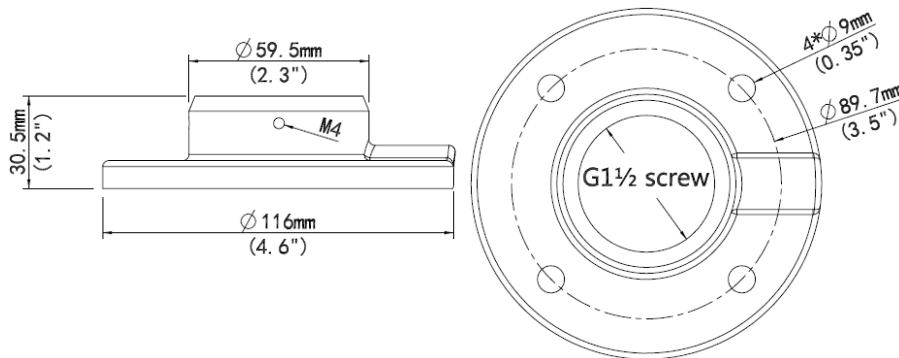

Specifications

Model	ESG-ASPMA1
Application	Indoor pendant mount adapter for Signature Series PTZ cameras (consult your sales rep for camera compatibility)
Dimensions	Φ116mm x 30.5mm (Φ4.6" x 1.2")
Weight	.3kg (.66lbs)
Material	Aluminium alloy

*ESG-ASPMA1 is also suitable for outdoor use if proper weatherproofing methods are followed carefully.

