

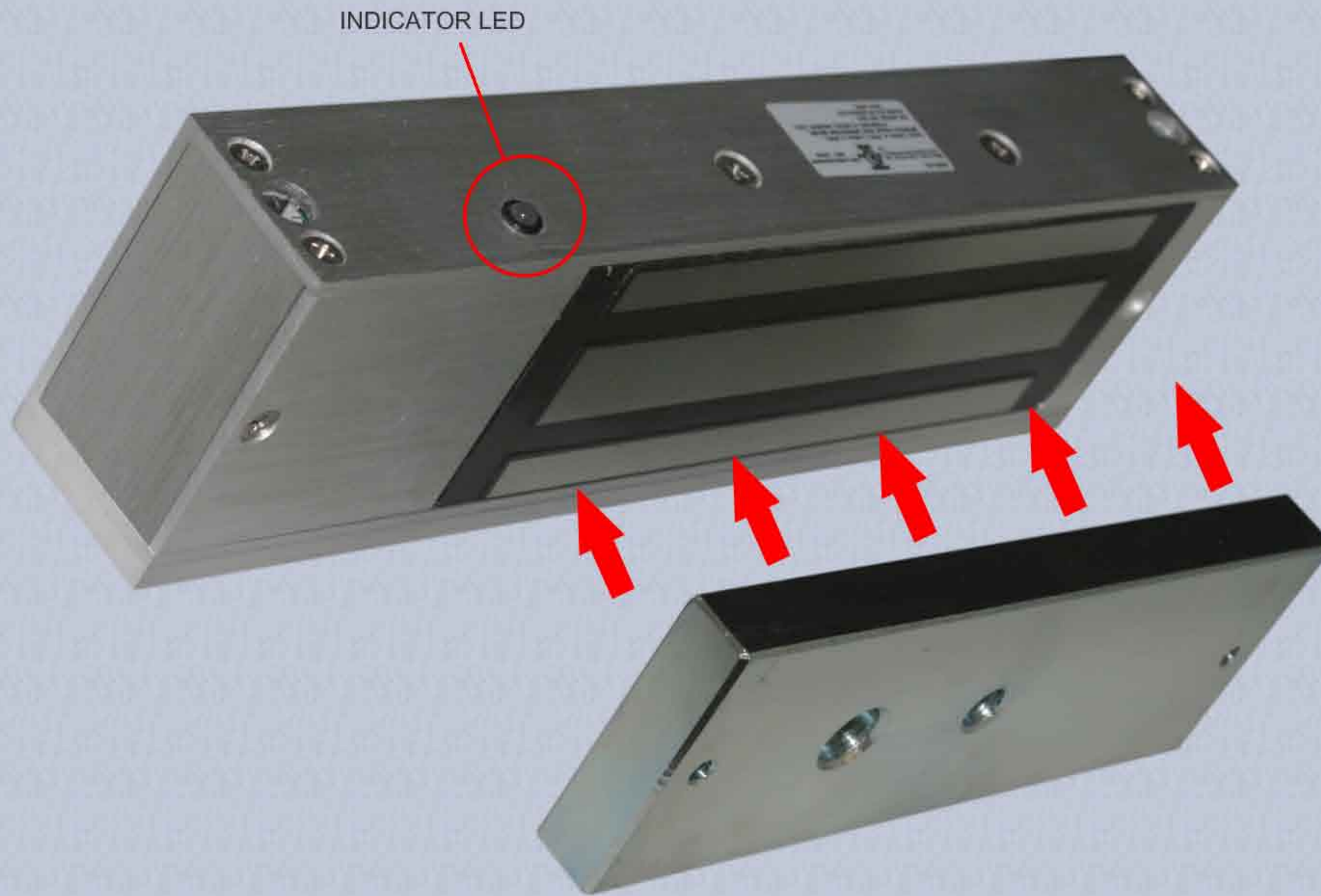

1200LB MAGNETIC LOCK

POWER OPTIONS | BUILT-IN PROTECTION | QUALITY DESIGN AND MANUFACTURING

ECL-ACC500



Our magnetic locks are widely used in commercial and industrial applications. They are perfect for use on doors and gates that close against a fixed stop. All of the lock components are carefully designed, manufactured, and tested to ensure superior quality.

- ✓ Apply 1200lbs holding force in an instant
- ✓ Heavy duty, aluminum alloy construction
- ✓ Release with no residual magnetism.
- ✓ Door template, instructions, installation hardware kit included

MODEL: ECL-ACC500

Design	Surface mount
Holding Force	1200 lbs.
Contact Relay	Built-In, terminal block connector
Protection	Built-in voltage spike suppressor
Indicator	LED
Power	12VDC or 24VDC
Current	360mA/12VDC, 180mA/24VDC
Warranty	3 years

Remove the side plate, if necessary for installation, using the tool provided.

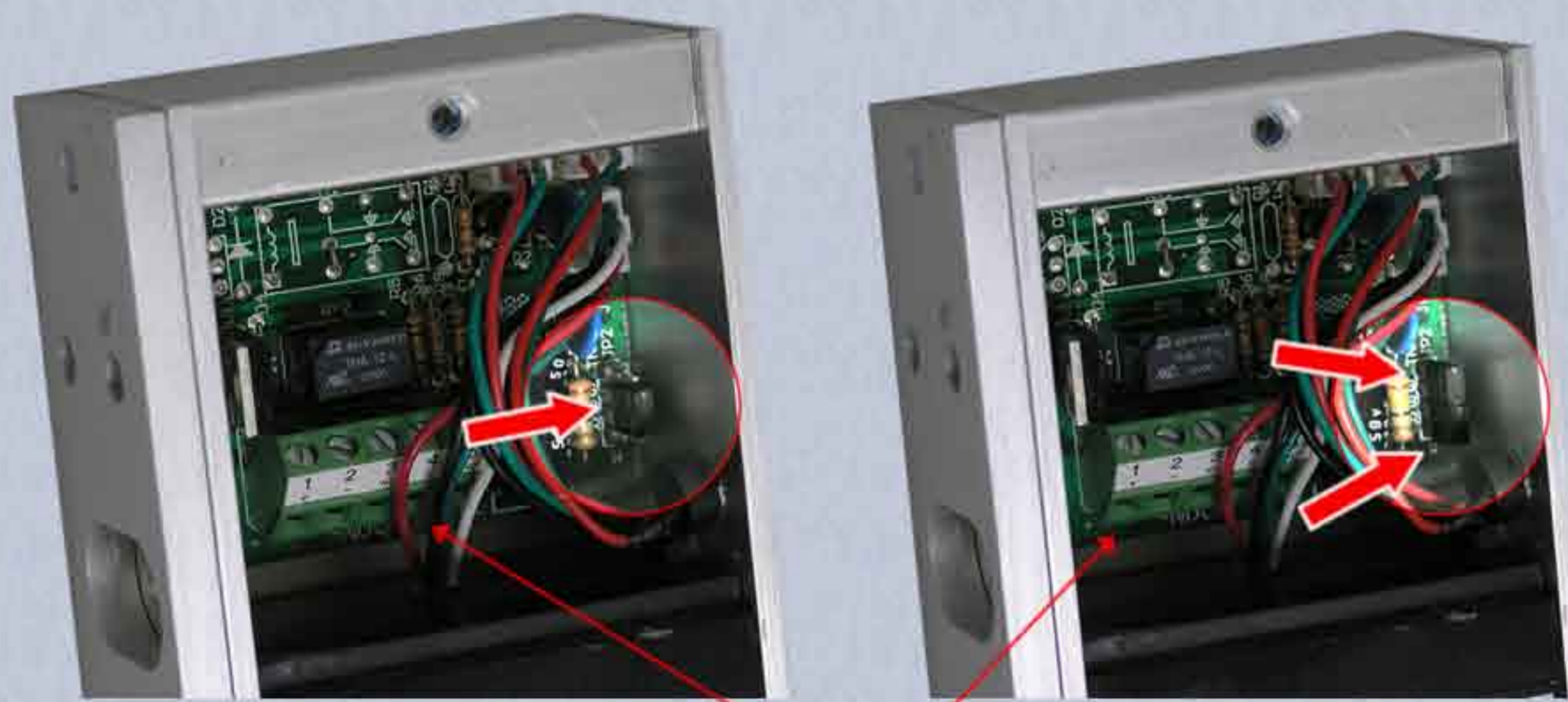

Jumper Setting for 24VDC Operation

Door Contact Relay

Jumper Setting for 12VDC Operation (Default Setting)

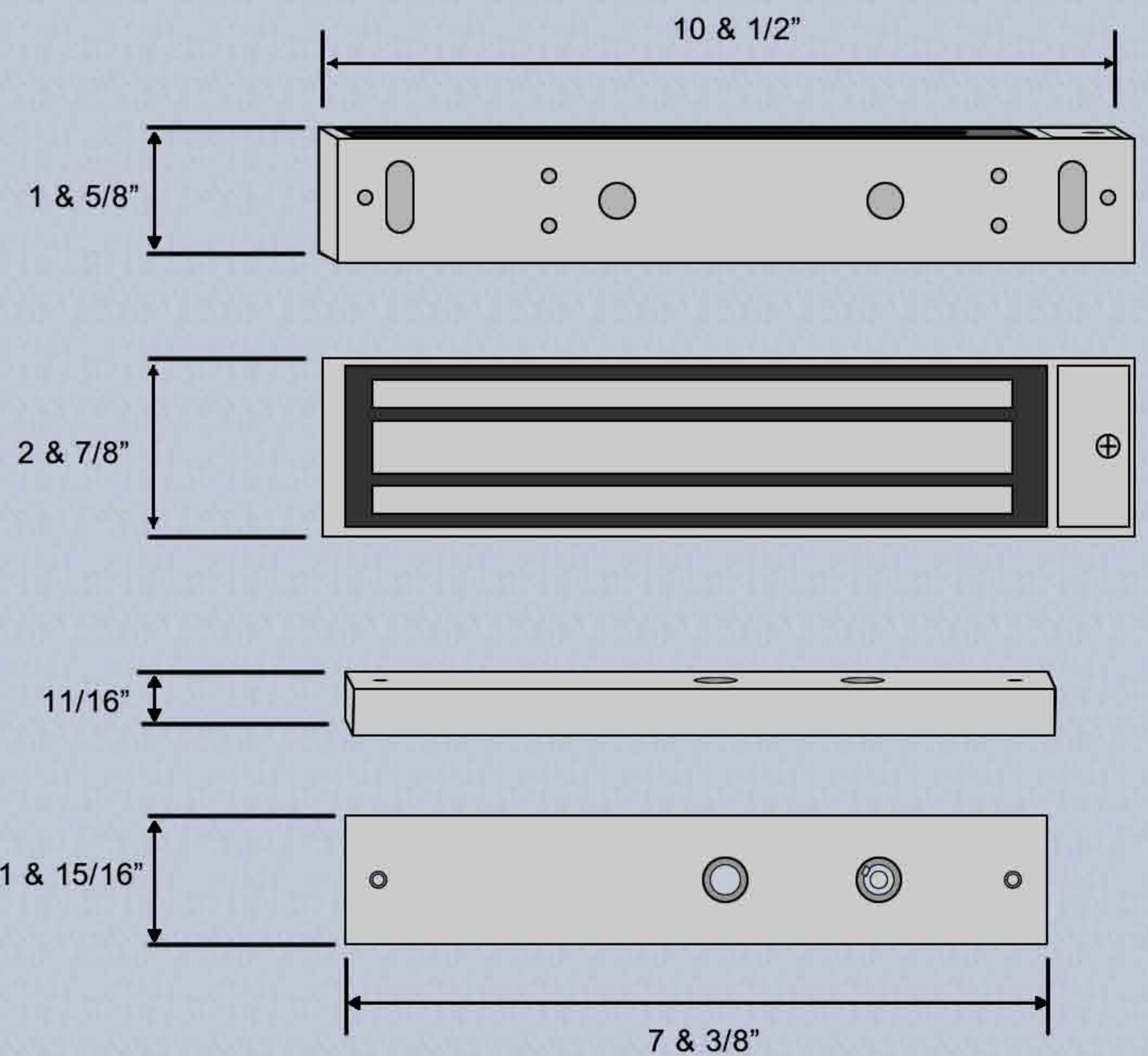

ASK A SALES REPRESENTATIVE ABOUT MAGLOCK ACCESSORIES AND OUR LATEST ACCESS CONTROL PRODUCTS

Z-Bracket for ECL-ACC500 Maglock



ECL-ACC12Z

L-Bracket for ECL-ACC500 Maglock

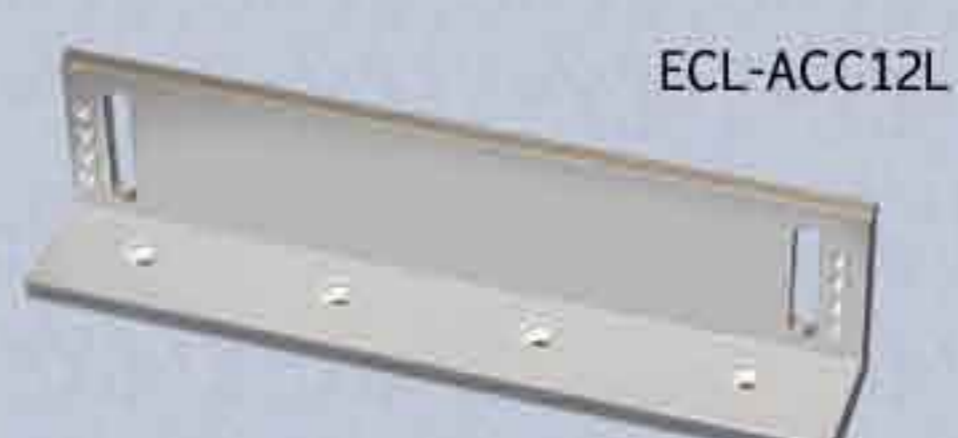

ECL-ACC12L

Glass Door U-Bracket for ECL-ACC500 Maglock



ECL-ACC16U

Video Doorbell Camera Monitors



Many Models to Choose From

Video Doorbell Cameras



Color & Monochrome Models